

KPCI-PIO32IOA KPCI-PDISO8A

32 and 16 Line, Optically Isolated, 0–60V, Digital I/O Boards



Optically isolated digital I/O boards

- Up to 32 optically isolated solid-state relays and digital inputs
- Direct, non-polarized switching and sensing; DC up to 60VDC, AC up to 30Vrms
- High load current capability up to 350mA
- High voltage transient protection
- Selectable low pass filter on inputs for AC or DC sensing
- External interrupt/latching capability
- 32-bit DriverLINX software includes test panel, ExceLINX, and DLL- and ActiveX-based drivers to use in programming languages such as Visual Basic, Visual C/C++, Delphi, LabVIEW, and TestPoint

The PCI bus based KPCI-PIO32IOA offers 32 lines of optically isolated digital I/O (16 inputs/16 outputs), while the KPCI-PDISO8A offers 16 lines of optically isolated digital I/O (8 inputs/8 outputs). These boards can directly switch and sense up to 60V, 350mA, which makes them ideal for controlling industry standard 12V, 24V, and 48V loads such as relays, valves, fans, lights, motors, and various solenoids. Their external interrupt and latching capability are designed for synchronizing digital inputs with other signals in the system. Like all members of the KPCI family, both include the 32-bit DriverLINX software for Windows.

These boards can be used in a wide variety of industrial monitoring, control, factory automation, and production test applications, such as controlling a motor in a robot or sensing contact closure in a security system. In an industrial monitoring and control environment, these boards could be used to monitor the status of a load and control the power in a closed loop fashion. In a factory automation and production test environment,

these boards could be used to control gates on a conveyor, monitor limit switches, control a component handler, flag a pass/fail alarm, or monitor and control binning and sorting mechanisms. The boards could also be integrated into a custom switching and control system that controls mechanical and RF relays.

Functional Description

The robust design of these boards includes on-board transient protection circuitry that absorbs the energy from high voltage spikes in the system. This increases the life of the product and protects it against unpredictable signals in the system.

The isolated, solid-state relays (FET switches) are designed for noisy production floors. The on-board optical isolation makes these boards more immune to noise and ground loops in the system. The solid-state switching provides longer life and lower maintenance compared to mechanical relays, especially in continuous process applications where switching is done frequently and around the clock.

These boards offer a digital input channel that can be used as an external interrupt to latch in data on a rising or falling edge.

ACCESSORIES AVAILABLE

CAB-1284CC-5	36-pin, half-meter Shielded Cable
CAB-1284CC-2	36-pin, two-meter Shielded Cable
MS-KPCIPIO32IO	Additional DriverLINX software CD for the KPCI-PIO32IOA and KPCI-PDISO8A
STP-36	36-pin Screw Terminal Panel
STP-ENCL	General purpose enclosure for the STP-36
TESTPOINT	Graphical, object-oriented, TestPoint Software Development Package

1.888.KEITHLEY (U.S. only)

www.keithley.com

KEITHLEY

A GREATER MEASURE OF CONFIDENCE

PCI/ISA/PCMCIA

KPCI-PIO32IOA KPCI-PDISO8A

Ordering Information

KPCI-PIO32IOA

16 outputs and 16 inputs, optically isolated, 0–60V, digital I/O board

KPCI-PDISO8A

8 outputs and 8 inputs, optically isolated, 0–60V, digital I/O board

32 and 16 Line, Optically Isolated, 0–60V, Digital I/O Boards

Condensed Specifications

Check www.keithley.com for more detailed specifications.

ISOLATED DIGITAL OUTPUTS

CHANNELS: 16 (on the KPCI-PIO32IOA) or 8 (on the KPCI-PDISO8A).

TYPE: Solid-state (MOSFET switches), optically isolated, N.O. Form A relays.

VOLTAGE RANGE: DC or AC, up to 60VDC, 30Vrms.

MAXIMUM LOAD CURRENT: 350mA.

ON-RESISTANCE: 3.5Ω typical (4Ω max.).

RELAY ON TIME: 1.0ms typical (3.5ms max.).

RELAY OFF TIME: 80μs typical (200μs max.).

LEAKAGE CURRENT: Typical 316nA at 60VDC, 50°C, 30% RH (2μA max.).

ISOLATED DIGITAL INPUTS

CHANNELS: 16 (on the KPCI-PIO32IOA) or 8 (on the KPCI-PDISO8A).

TYPE: Solid-state, optically isolated.

VOLTAGE RANGE: DC or AC, up to 60VDC, 30Vrms (DC logic high: $>|\pm 2.5V|$, logic low: $<|\pm 1.0V|$).

RESPONSE TIME: 0.6ms typical (1.0ms max.).

SELECTABLE LOW PASS FILTER FOR AC OR DC SENSING: 175ms time constant, jumper selectable.

GENERAL

ISOLATION: 60V channel to channel and channel to chassis.

ENVIRONMENTAL:

Operating Temperature: 0 to 50°C.

Storage Temperature: –20 to 70°C.

Humidity (non condensing): 0 to 80% at 35°C.

POWER: 500mA max. required by the card (additional 1A can be drawn from pin 1, +5V).

EMC: Conforms to European Union Directive 89/336/EEC, EN61326-1.

SAFETY: Conforms to European Union Directive 73/23/EEC, EN61010-1.

DIMENSIONS OF BOARD: 18.1cm × 10.8cm × 1.9cm (7.1 in × 4.25 in × 0.75 in).

DIMENSIONS OF STP-36 ACCESSORY: 133mm × 72mm × 32mm (5.25 in × 2.75 in × 1.25 in).

CONNECTORS: Board connector part number by 3M: N10236-52B2VC. Mating connector by 3M: 10136-6000EC (IDC), 10136-3000VE (solder).

Configuration Guide

*Only one STP-36 screw terminal and one CAB-1284CC-2 cable is needed for the KPCI-PDISO8A.

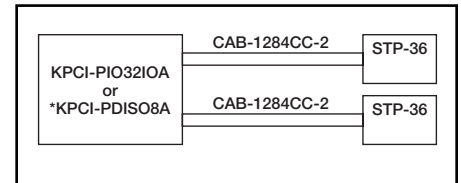

Connector Pin Assignments

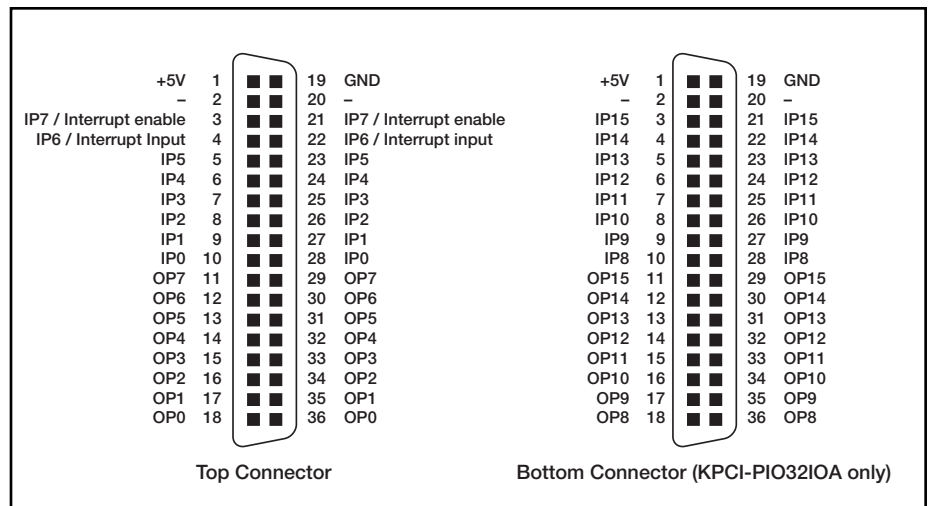

1.888.KEITHLEY (U.S. only)

www.keithley.com

KEITHLEY

A GREATER MEASURE OF CONFIDENCE

Optically isolated digital I/O boards

PCI/ISA/PCMCIA